



Max Lifting
Height 8.7m

Working Radius 8.2m

Capacity
2.82t x 1.4m

Weight
1960-2120kg

MC285



MC285

The MC285 boxes way above its weight with a massive 2.82 ton lifting capacity while measuring just 750mm wide when stowed. Its slim body is able to fit through most doorways allowing access to areas previously inaccessible to standard cranes. The MC285 has proven to be one of the most popular models of mini crane and is used in many varied applications. The latest version of the MC285 model features improved safety features, a 4/2 fall hook block as standard and is faster and easier to operate than ever before.

- 2.82 Ton Max Capacity
- 8.7m Max Working Height
- Super Slim Body Width (750 mm)
- Outrigger Interlock System
- Low ground pressure
- Manoeuvrability & Stability
- Programmable Moment Limiter
- Hydrostatic Transmission
- 4/2 Fall Hook Block
- Tilt Alarm
- Digital Feedback Remote Control System
- Powerful Winch with Hydraulic Disc Brake
- Optional 300kg / 850kg Searcher Hook
- Optional Auxiliary winch for work below ground level of 100m
- Data Logger
- 2 Year Warranty

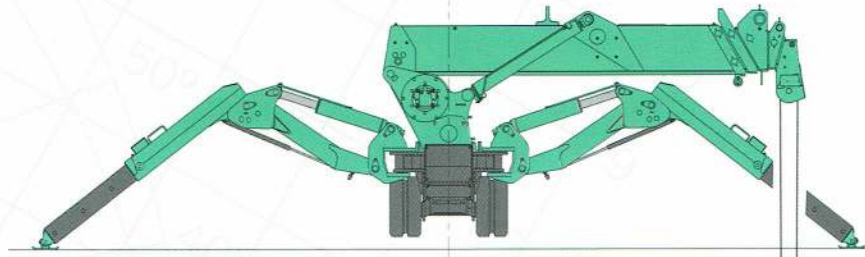

MC285C-2 Outriggers Position : Max

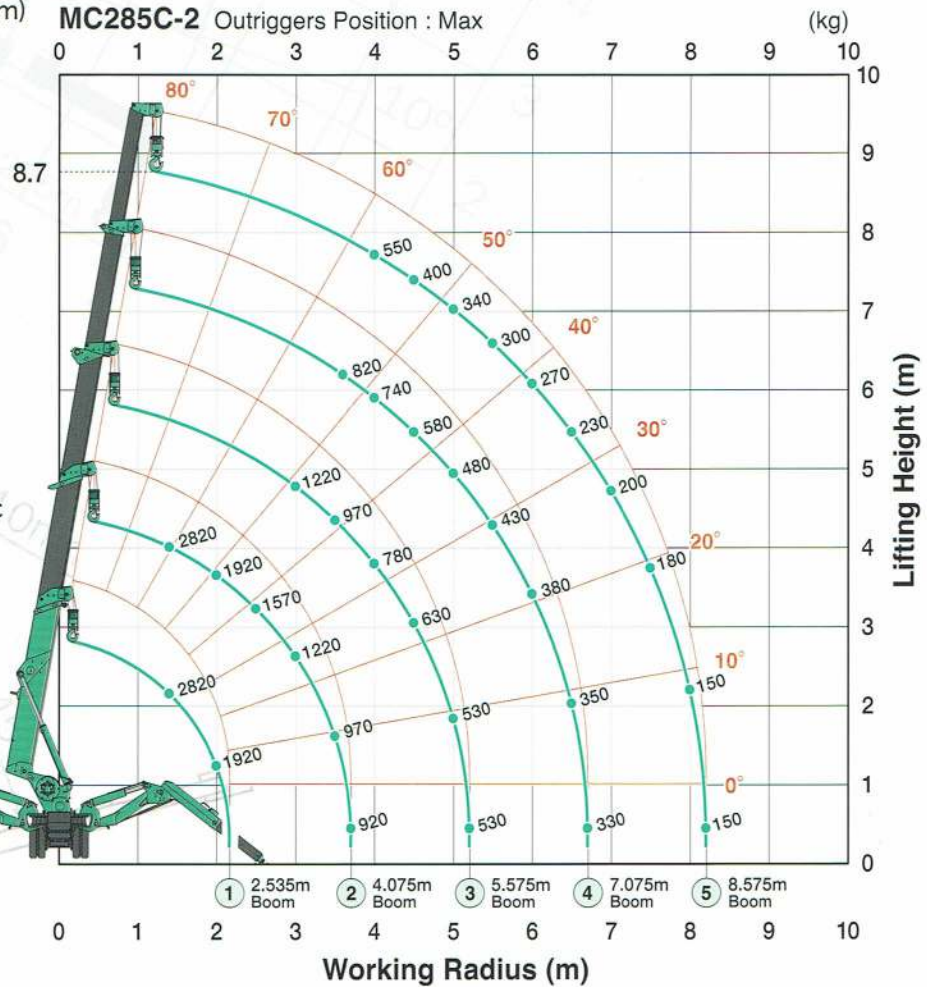

This working range chart shows total rated load including boom deflection.

4 Fall
10.1m



2 Fall
20.2m



Single Fall
40.4m



Aux winch
(Single fall)
100.0m

... consider the possibilities



Total rated load with Outriggers at Maximum position with 850kg Searcher Hook

Working radius (m)	Total rated load(kg)				
	2.535m boom	2.536-4.075m boom	4.076-5.575m boom	5.576-7.075m boom	7.076-8.575m boom
1.5	850	850			
2.0	850	850			
2.5	850	850			
2.6	850	850			
3.0		850	850		
3.5		850	850		
3.6		830	850	690	
4.0		830	850	690	460
4.1		830	730	640	430
5.0			540	500	350
5.5			440	420	310
5.6			420	400	300
6.0				360	270
6.5				320	230
7.0				290	200
7.1				280	180
7.5					170
8.0					150
8.5					130
8.61					120

Total rated load Outriggers at Maximum position

2.53m/4.075m boom		5.575m boom		7.075m boom		8.575m boom	
Working radius (m)	Total rated load(kg)	Working radius (m)	Total rated load(kg)	Working radius (m)	Total rated load(kg)	Working radius (m)	Total rated load(kg)
< 1.4	2820	< 3.0	1220	< 3.6	820	< 4.0	550
1.5	2520	3.5	970	4.0	740	4.5	400
2.0	1920	4.0	780	4.5	580	5.0	340
2.5	1570	4.5	630	5.0	480	5.5	300
3.0	1220	5.0	530	5.5	430	6.0	270
3.5	970	5.205	530	6.0	380	6.5	230
3.705	920			6.5	350	7.0	200
				6.705	330	7.5	180
						8.0	150
						8.205	150

Total rated load Outriggers at any other position

2.53m/4.075m boom		5.575m boom		7.075m boom		8.575m boom	
Working radius (m)	Total rated load(kg)	Working radius (m)	Total rated load(kg)	Working radius (m)	Total rated load(kg)	Working radius (m)	Total rated load(kg)
< 1.5	1720	< 3.0	510	< 3.6	400	< 4.0	330
2.0	1070	3.5	410	4.0	330	4.5	280
2.5	630	4.0	330	4.5	280	5.0	230
3.0	520	4.5	280	5.0	230	5.5	180
3.5	430	5.0	230	5.5	180	6.0	160
3.705	350	5.205	200	6.0	160	6.5	150
				6.5	150	7.0	100
				6.705	140	7.5	80
						8.0	70
						8.205	60

Outrigger Footprints

Diagram shows outriggers at maximum position.

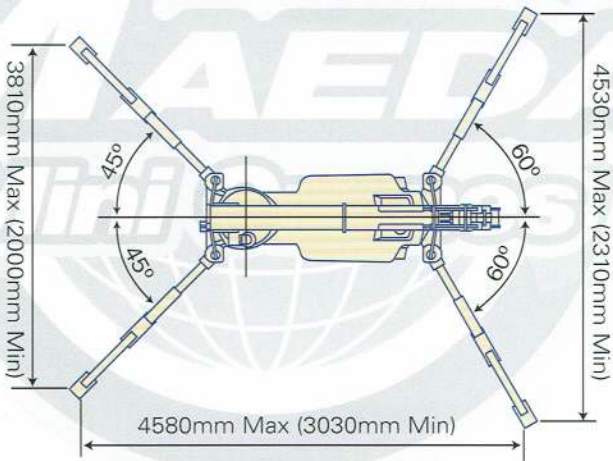

- When using two fall or single fall hooks, use the appropriate four fall Total Rated Load Chart but with a maximum load of:
Two Fall - 1410kg, Single Fall - 710kg.

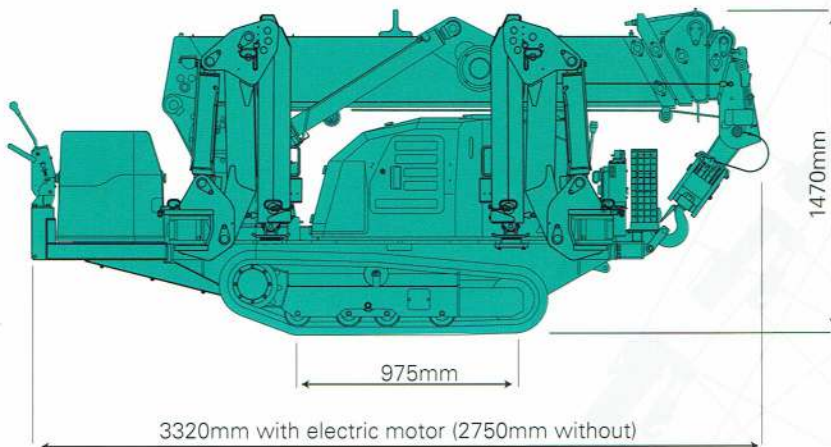
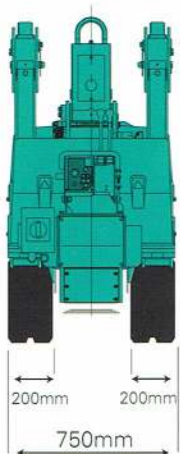

MC285

Specifications

Capacity	Maximum	2.82 t x 1.4m
Working radius	Maximum	8.205m x 150kg
Lifting height	Maximum	8.7m x 550kg
Dimensions	MC285 CRM	2750mm x 750mm x 1470mm
	MC285 CRME	3320mm x 750mm x 1470mm
Weight	MC285 CRM	1960kg
	MC285 CRME	2120kg
	Hook block weight	30kg
Hook speed	Maximum	9.3m / min. (4 falls, 4th layer)
Single line speed	Maximum	37.2m / min. (4th layer)
Hoist rope	Type	IWRC 6 x Fi (29) Ø 7mm x 48m
Telescopic system	Boom length	2.535m - 8.575m
	Telescoping speed	6.04m / 22 sec.
	Boom type	Fully automatic 5 section pentagonal telescopic boom
Boom hoist system	Hoist angle / speed	0° - 80° / 14 sec.
Slew system	Slew angle / speed	360° continuous / 1.0 rpm
Outrigger system	Type	1st stage with flexible stay damper, 2nd stage manual pullout, hydraulic cylinder direct acting type
	Maximum outriggers	(Length) 4580mm x (Front) 4530mm x (Rear) 3810mm
Traction system	Drive	Hydraulic motor driven, stepless speed changer
	Travel speed	0 - 2.2 km/h
	Gradability	20°
	Ground length x width	975mm x 200mm (Track dimensions)
	Ground pressure	0.497 kgf / cm ² (0.537 kgf / cm ² CRME)
Engine	Model	Yanmar 2TNV70-NMBA
	Type	2 cylinder water cooled diesel
	Rated output	7.4 kW / 2500 rpm
	Starting method	Electric
	Fuel tank capacity	Diesel / 12L
Electric motor (Optional)	Type	Fully enclosed fan cooled motor
	Size	5.5 kW 4P 380V
Safe load indicator	Made specifically for Maeda Mini Cranes with a fully programmable working envelope	
Standard equipment	Overwind protection, hour meter, digital feedback remote control, black rubber tracks, hydraulic safety valves, level, tilt alarm, EMO switch, moment limiter, working status lamp, data logger, outrigger interlock system, 4-fall / 2-fall hook block	
Optional equipment	White rubber tracks	
	Single fall hook	
	300kg / 850kg searcher hook	
	Radio remote control	
	Slew restrictor	
	Engine heater	
	Hydraulic heater	
	Spark arrestor	
	900kg Auxiliary winch	

